



Scientific

24" Signature Series Freezer and Refrigerator Specification Sheet

Model Numbers

Freezer	Refrigerator
<input type="checkbox"/> HP24FS-1L	<input type="checkbox"/> HP24RS-1L
<input type="checkbox"/> HP24FS-5	<input type="checkbox"/> HP24RS-3L
	<input type="checkbox"/> HP24RS-5



HP24FS-1R



HP24FS-5

Freezer Features:

- Perlick's exclusive 1,000 Btu Variable Speed Compressor
- Front-vented, forced-air refrigeration results in precise temperature control
- Industry exclusive full-extension shelves
- Industry exclusive stainless steel interior
- Interior digital display
- Equipped with automatic hot gas defrost for maintenance-free defrosting
- Door locks are available
- Two-year full warranty on complete unit – Additional four-year limited warranty on the sealed refrigeration system
- Available with a solid stainless steel door, solid wood overlay door, two stainless steel drawers or two wood overlay drawers
- Freezer temperature -10 to 10 degrees F
- Precise temperature control: thermal mass temperature is held to within 1 degree
- 5.3 cubic feet of capacity



HP24RS-1L



HP24RS-5



HP24RS-3L

Refrigerator Features:

- Perlick's exclusive 1,000 Btu Variable Speed Compressor
- Front-vented, forced-air refrigeration results in precise temperature control
- Industry exclusive full-extension shelves
- Industry exclusive stainless steel interior
- Low-E, UV-coated glass provides leading insulation and protection
- Interior digital display
- Door locks are available
- Two-year full warranty on complete unit – Additional four-year limited warranty on the sealed refrigeration system
- Available with a solid stainless steel door, solid wood overlay door, two stainless steel drawers or two wood overlay drawers
- Refrigerator temperature 33 to 39 degrees F
- Precise temperature control: thermal mass temperature is held to within 1 degree
- 5.3 cubic feet of capacity

Quality YOU DESIRE.
RELIABILITY YOU CAN'T LIVE WITHOUT.



8300 W. Good Hope Rd. • Milwaukee, WI 53223

1-800-558-5592 • Fax: (414) 353-7069 • www.Perlick.com

Perlick is committed to continuous improvement. Therefore, we reserve the right to change specifications without warning

Indoor Models	Freezers
HP24FS-1L	24" Freezer with solid stainless door
HP24FS-2	24" Freezer with solid stainless drawers
Indoor Models	Refrigerators
HP24RS-1L	24" Refrigerator with solid stainless door
HP24RS-3L	24" Refrigerator with glass door with stainless trim
HP24RS-5	24" Refrigerator with solid stainless drawers

Job _____
 Area _____
 Item No. _____
 Model No. _____

Models are specified as left hinge, right hinge is optional.

Overall Width: 23-7/8", 60.643 cm
Overall Height: 34-5/16", 87.154 cm
Overall Depth: 23-15/16", 59.214 cm
Capacity: 5.3 cubic ft.
Minimum Height Required: 34-1/8"
Door Swing Clearance: 24-25/32"
Annual Energy Usage: Freezer: 414 kW/yr
 Refrigerator: 308 kWh/yr
Electrical: 115V, 60 Hz., 1 phase AC, 2.3 amps
Plumbing: none required
Shipping Weight: 215 lbs., 97.522 kg

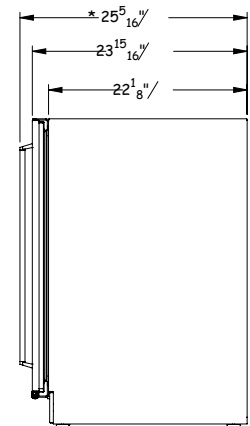
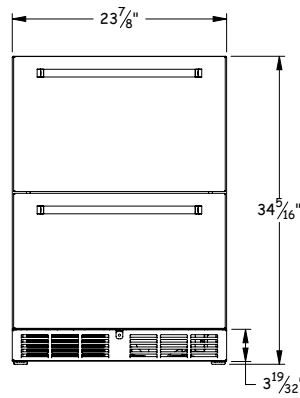
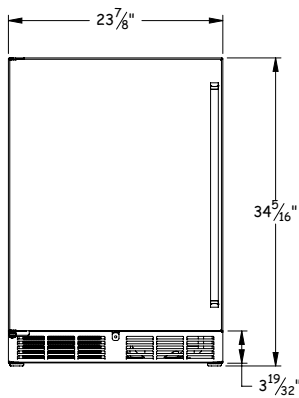
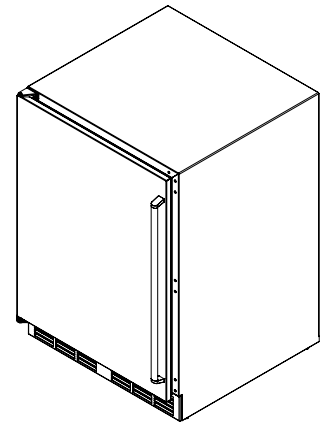
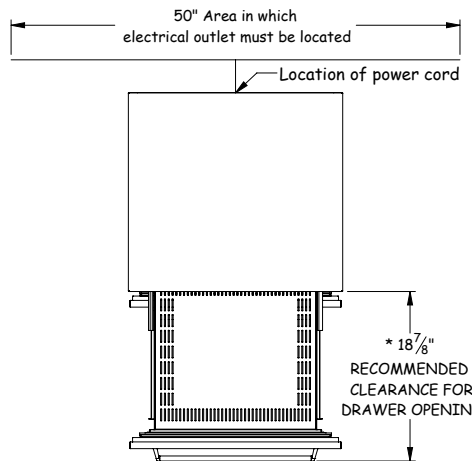
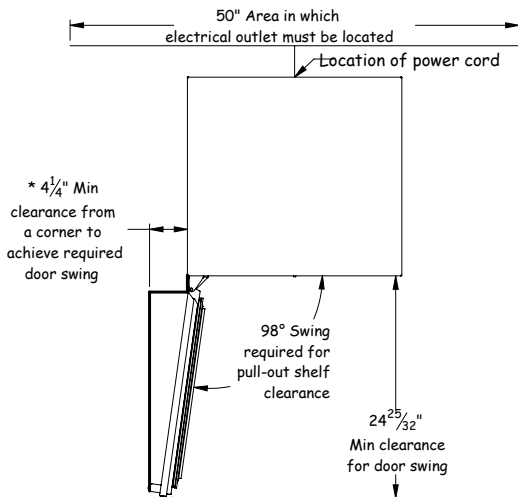
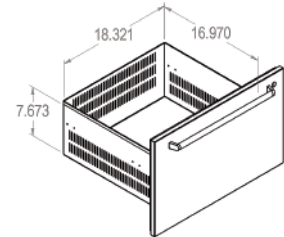
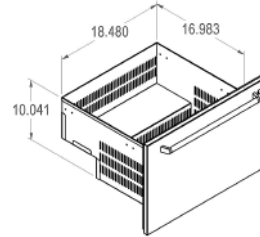

* - Values may change due to custom pull with a wood overlay door



8300 W. Good Hope Rd. • Milwaukee, WI 53223
 1-800-558-5592 • Fax: (414) 353-7069 • www.Perlick.com

Perlick is committed to continuous improvement. Therefore, we reserve the right to change specifications without warning