



24" Signature Series Freezer Specification Sheet

Model Numbers

- HP24FS-1 HP24FO-1
- HP24FS-2 HP24FO-2
- HP24FS-5 HP24FO-5
- HP24FS-6 HP24FO-6



HP24FS-1R



HP24FS-5

Features:

- Designed with fully-integrated depth to allow flush fit with surrounding cabinetry (with 3/4" wood overlay)
- Zero-clearance hinging allows for abutment with surrounding cabinetry
- Perlick's exclusive Variable Speed Compressor
- Front-vented, forced-air refrigeration
- Industry Exclusive full-extension shelves
- Industry Exclusive stainless steel interior
- Two (2) year full warranty on complete unit – Additional four year limited warranty on the sealed refrigeration system
- Maintenance-free automatic defrost cycle
- Industry Exclusive Convertible Door Design allows all doors to be converted to wood overlay from stainless steel
- Door locks available
- Interior digital display
- Freezer equipped with automatic hot gas defrost for maintenance-free defrosting
- Interior digital display system
- Adjustable full-extension shelving allow easy storage and access to goods
- Available with a solid stainless steel door, solid wood overlay door, two (2) stainless steel drawers or two (2) wood overlay drawers
- Freezer temperature -10 – 10 degrees F
- 5.3 cubic feet of capacity

Luxury YOU DESIRE.
INNOVATION YOU CAN'T LIVE WITHOUT.



8300 W. Good Hope Rd. • Milwaukee, WI 53223

1-800-558-5592 • Fax: (414) 353-7069 • www.Perlick.com

Perlick is committed to continuous improvement. Therefore, we reserve the right to change specifications without warning

Indoor Models	Outdoor Models	Freezers
HP24FS-1	HP24FO-1	24" Freezer with solid stainless
HP24FS-2	HP24FO-2	24" Freezer with solid wood overlay door
HP24FS-5	HP24FO-5	24" Freezer with solid stainless steel drawers
HP24FS-6	HP24FO-6	24" Freezer with wood overlay drawers

Job _____
Area _____
Item No. _____
Model No. _____

Overall Width: 23-7/8", 60.643 cm
Overall Height: 34-5/16", 87.154 cm
Overall Depth: 23-15/16", 60.801 cm
Capacity: 5.3 cubic ft.
Minimum Height Required: 34-3/8"
Door Swing Clearance: 24-25/32"
Annual Energy Usage: 414 kWh/yr
Electrical: 115V, 60 Hz., 1 phase AC, 2.3 amps
Plumbing: none required
Shipping Weight: 215 lbs., 97.522 kg

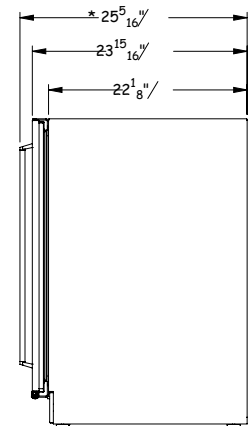
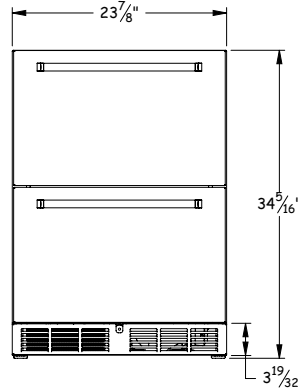
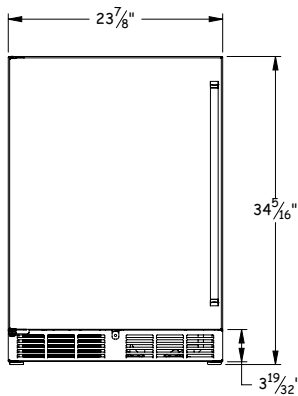
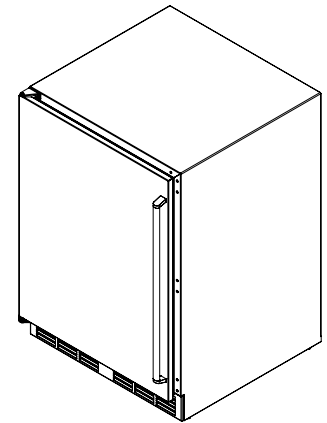
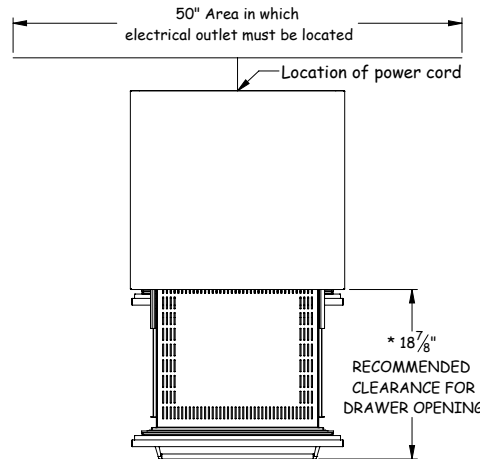
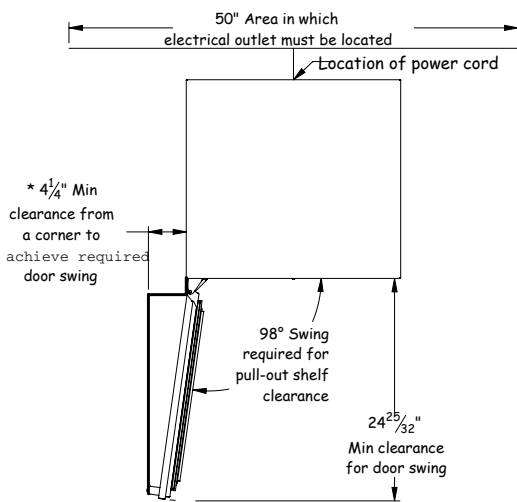
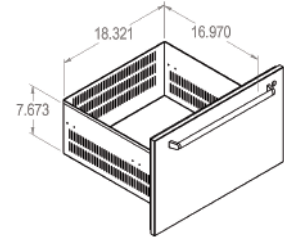
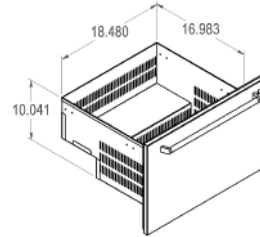

* - Values may change due to custom pull with a wood overlay door



8300 W. Good Hope Rd. • Milwaukee, WI 53223

1-800-558-5592 • Fax: (414) 353-7069 • www.Perlick.com

Perlick is committed to continuous improvement. Therefore, we reserve the right to change specifications without warning