

FRONT VIEW

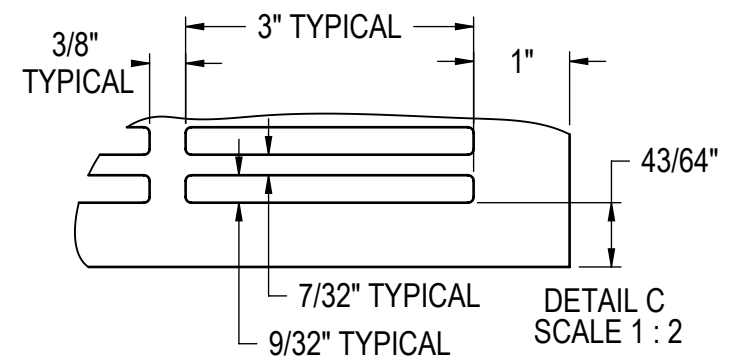

**DETAIL C
SCALE 1 : 2**

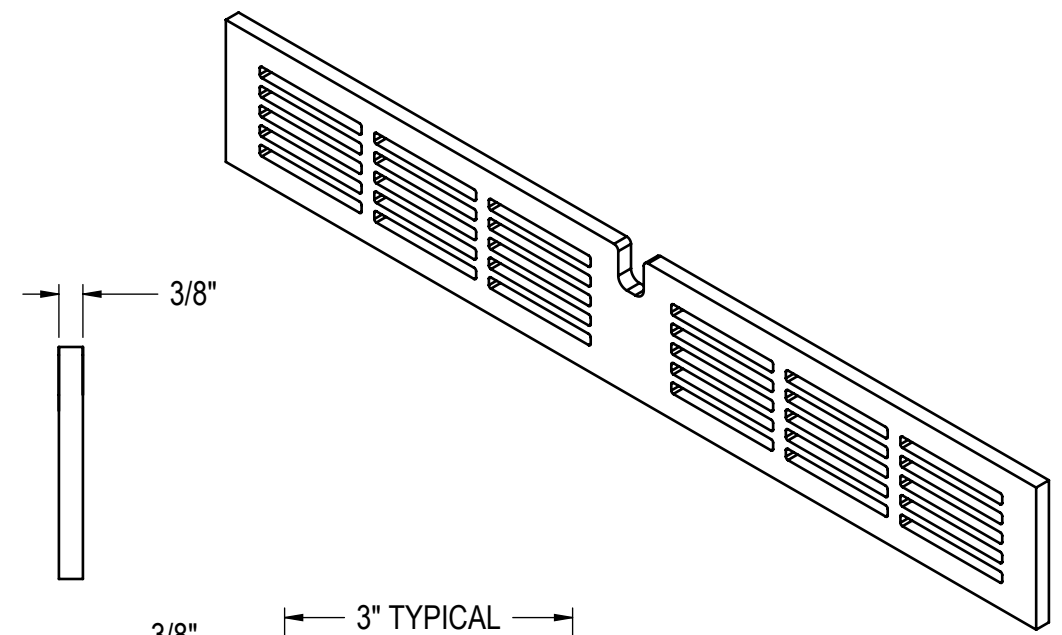
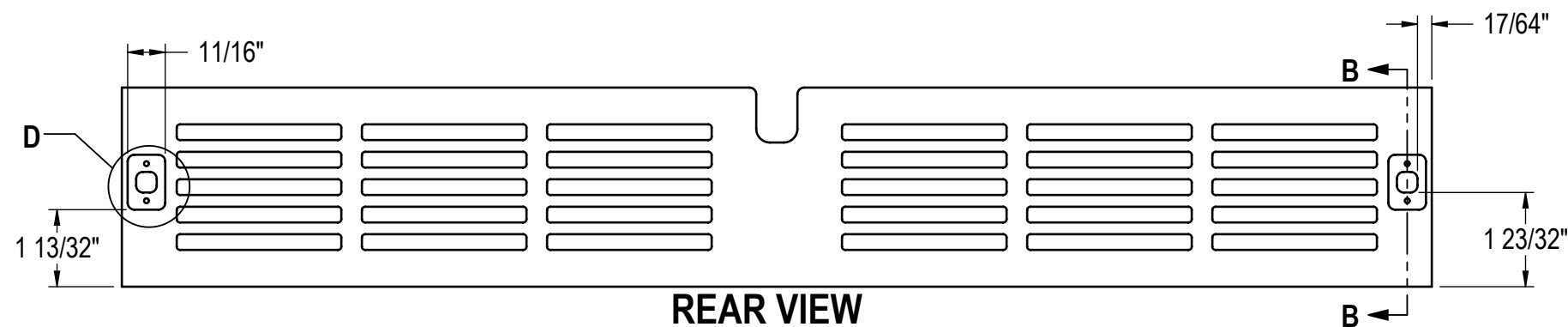

REAR VIEW

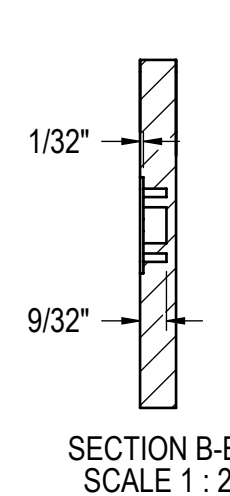

**SECTION B-B
SCALE 1 : 2**

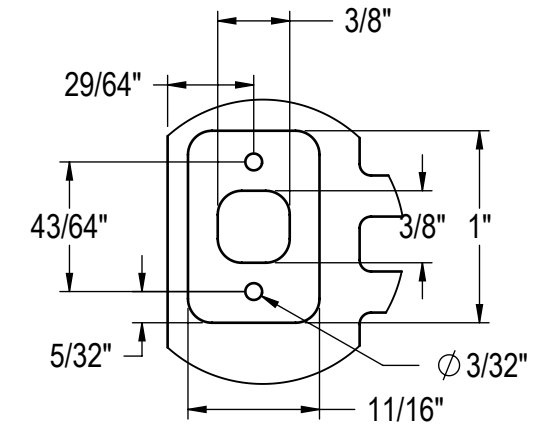

**DETAIL D
SCALE 1 : 1**

NOTE: ALL INTERNAL RADII ARE 1/8IN UNLESS OTHERWISE SPECIFIED

4/23/2008
REVISIONS

UNLESS OTHERWISE SPECIFIED: DIMENSIONS ARE IN INCHES TOLERANCES: .X = ±.05, .XX = ±.01, .XXX = ±.005, ANGULAR: ±.5°, FRACTIONS: ±1/64 BREAK SHARP EDGES - .015 X 45°. RADIUS SHARP FILLETS - .015 TO .031	SIGNATURES	DATE	Perlick Corporation Milwaukee, Wisconsin TITLE: GRILL, WOOD STACKING
	DESIGNED NAH	4/23/2008	
	DRAWN NAH	4/23/2008	
	CHECKED	4/23/2008	REFERENCE: PART NO. WOOD GRILL, STACKING DWG NO. WOOD GRILL, STACKING PURCHASE REC.: SCALE = 1:3 SHEET 1 OF 1
MATERIAL: WOOD	QTY.: FINISH:		

THIS DOCUMENT / PUBLICATION / SOFTWARE / DRAWING CONTAINS PROPRIETARY INFORMATION WHICH IS THE PROPERTY OF THE PERLICK CORPORATION. IT MAY NOT BE REPRODUCED OR TRANSMITTED IN ANY FORM, ELECTRONIC OR MECHANICAL, INCLUDING PHOTOCOPYING, RECORDING, OR USED IN ANY INFORMATION STORAGE, TRANSMISSION, OR RETRIEVAL SYSTEM, WITHOUT WRITTEN PERMISSION FROM THE PERLICK CORPORATION. COPYRIGHT 2001 PERLICK CORPORATION. ALL RIGHTS RESERVED.